



# Edge<sup>3</sup>

Color LCD  
Depth Sounder  
Model LC-507C

Owner's Manual



## CONTENTS

Introduction	2
Specs & Features	3
Installation	4
Connecting to Power	4
Transom Transducer Installation	4
Electric Trolling Motor Transducer Installation	5
In-Hull Transducer Installation	6
Temperature Probe Installation	6
Unit Operation	7
Understanding the Display	7
Control Panel Keys	9
Menu Functions	10
Accessories & Replacement Parts	15
Trouble Shooting	16
Service	16

## INTRODUCTION

### The Concept

The whole idea of the Edge<sup>3</sup> is the ability to see the same thing using two different types of sonar. The Edge<sup>3</sup> is actually two depth sounders built into one unit. Each sounder has it's own advantages. The goal is to give you the best of both worlds so that you can know more about what's underneath your boat.



### TRUE Dual Frequency / Dual Beam Operation

The Edge<sup>3</sup> is not your run-of-the-mill dual frequency depth sounder. You truly have two separate sounders with two separate transducers with separate controls.

### 107 kHz Depth Sounder

The first of the two sounders uses a 107 kHz frequency with a 38° cone angle. This low frequency gives you a lot of power throughout the very wide cone. Low frequencies have an edge over higher frequencies by being able to cover a lot of area and reach into deep water much more efficiently. Lower frequencies also tend to filter out targets of very small size.

### 400 kHz Depth Sounder

The other half of the Edge<sup>3</sup> uses a 400 kHz frequency offering a 10° cone angle. This high frequency gives a very tight cone for amazing precision. Higher frequencies have an advantage over lower frequencies for these reasons. Higher frequencies will also see small targets the low frequencies miss.

Vexilar reserves the right to modify the features and specification described within this manual at any time and without notice.

## Separate Controls to Fine-Tune Each View

Because the two sounders act so differently, separate controls allow you to make each show you what you want to see. For example, you would generally keep the gain much lower on the 107 than the 400 in the same depth of water. Also, you may be very interested in bottom content, yet at the same time want to see the entire water column with the best view. With separate controls, you can set the range on the 107 to best show bottom content and multiple echoes while keeping the 400 set to show from the bottom up.

## Ease of Use

The biggest problem with most high-end sounders these days is the complexity of the controls and menus. The Edge<sup>3</sup> reduces this problem significantly by giving you front panel controls for the most important functions, plus Modes that let you set up the system for different situations. These Modes save your front panel and menu settings. When you hit the Mode button to change to a new Mode, your setting for the last Mode are saved. A common practice is to set up your modes the way you want, and from then on, simply turn the unit on and switch between your Modes.



## SPECS & FEATURES

Display: 16-Color 320 x 240 TFT (4-3/4" x 3-3/4")

Frequency: 107 kHz & 400 kHz

Cone Angle: 38° (107 kHz) & 10° (400 kHz)

Resolution: 2" Minimum

Power: 1600 Watts of Peak-to-Peak Power

Speed: 40 Pixel/Second Max

Voltage Requirement: 11 - 35 Vdc

Current Draw: 1.25 Amps Max

Size: 9-1/4" W x 8-1/2" H x 3-3/8" D

Weight: 3-3/4 Lbs

## Features

- 4 User Modes
- "Favorite Feature" Key
- "Instant High-Speed" Key
- "Previous View" Memory
- Front Panel Auto/Manual Range
- Front Panel Auto/Manual Gain
- Front Panel Clean Line Control
- 107 & 400 Composite Feature
- 4 Optional Background Colors
- 6 Optional Signal Color Schemes
- x2, x4, or x8 Split Screen Zoom
- Auto or Selectable Zoom Zone
- Bottom Hardness Graph
- Selectable Pulse Length
- Selectable STC
- Multiple Echo Control
- Auto-Gain Level Control
- Fish Alarm
- Hard Bottom Alarm
- Temperature Probe
- Voltage Indication
- Clean Line
- Temp Zone Alarm
- Super-Bright Backlight
- 2-Year Warranty

## Depth Ranges

2', 3', 5', 7', 10', 15', 20',  
25', 30', 35', 40', 50', 60',  
70', 80', 100', 120', 150',  
and 200'

## INSTALLATION

You will need to find a place to mount the unit that will make it easy to view and reach. You must provide the unit with power and mount the transducer and temp sensor in an effective location.

### Mounting the Unit

Find a convenient place to mount the unit. Make sure that there is plenty of room for the unit to tilt freely without the cables binding or stretching behind the unit. Once you have found the spot, remove the unit from the gimbal bracket and securely attach the bracket to the mounting surface. The screws provided are for wood/carpet or dash mounting applications. If you want to use an optional removable swivel bracket, be sure it's able to support the weight of this unit.

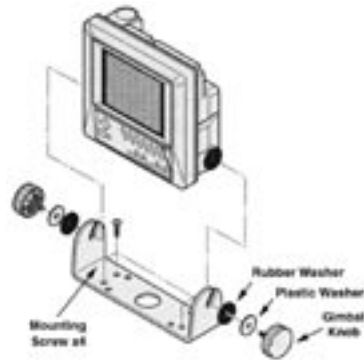

A Decorative Wire Cover has been included to help make your rigging job look good. Use this to cover up the large hole you'll need to drill to fit the transducer, temperature probe, and power connectors through.

### Connecting the Power

Plug the 2 pin connector into the back of the unit. Find the closest source of 12 volts and route the cord to it. Keep the cord away from sharp metal edges and avoid tight places where the cord may get crushed. Connect the white wire to positive and the black wire to negative. If the cord provided is not long enough, more can be added. Use 18 gauge wire minimum. Install a 2 amp in-line fuse, placed in the positive line, as close to the power source as possible, to protect against shorts in the wiring.

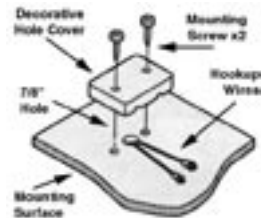

## MOUNTING THE TRANSDUCERS

The transducer mounting method will depend on which version of the Edge<sup>3</sup> you purchased. In either version, it is important to mount the two transducers as close together as you can. This will insure your Edge<sup>3</sup> gives you the information it was design to offer.

- LC-507C TM - Transom Mount Transducers
- LC-507C ETM - Trolling Motor Mounted Transducers
- LC-507C IH - In-Hull Mounted Transducers

### Transom Mounting

Locate the transducers and bracket hardware. Each transducer has a mounting bracket assembly which includes;

- 2 Angle Brackets
- 4 Bracket Screws
- 4 Washers
- 4 Nuts
- 4 Mounting Screws

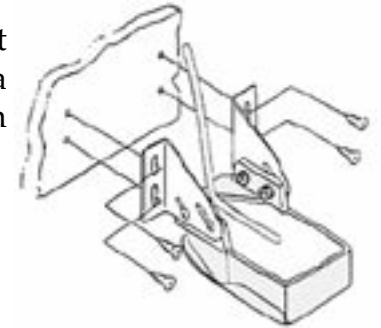

Attach the bracket to the transducer as shown in Figure 5. The flanges of the bracket normally point outward, away from the transducer. If mounting space is tight, you can reverse the angle brackets and face the flanges inward.

Locate a spot for each transducer similar to the one shown. If your boat hull has a significant rise (more than 10°), you should mount the transducer so the bottoms are parallel to the water line. If your boat hull is level, or has only a small rise, you should keep the bottom of the transducers parallel with the hull

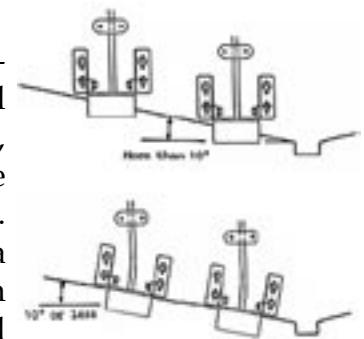

line. Keep in mind that you need clear water flow across the face of the transducers to insure a clear reading at all speeds. Stay away from rivets, ribs, or strakes that would be just in front of the transducers. They will disturb the water and scramble the reading. The 107 kHz transducer is more susceptible to this effect than the 400 kHz transducer, so it is a good idea to place it closer to the center of the transom where smooth water flow is easier to maintain.

After you attach each mounting bracket to each transducer, hold it up to the boat where you are planning to mount it. Mark the four holes on the transom, or mounting plate, so that when the bottom of the transducer is flush with the bottom of the boat the holes are located at the bottom of the bracket slots. This gives you room to "fine tune" the position of the transducer downward and optimize your reading after you've put the boat back in the water. Drill out the holes and install the transducer bracket assembly. Tighten the screws down securely. Be sure to seal any holes drilled into the transom with silicone to prevent water from leaking into the boat.

Route the transducer cord up to the unit taking the same care as you did when you routed the power cord. Make sure that the cord is restrained and not allowed to flop around in the wind. This can cause stress on the wire inside the cable, and possible breakage. Plug the transducer connector into the back of the unit and screw the retaining ring down tight. Make sure the frequency labeled on the transducer cable matches the frequency labeled on the transducer jack on the unit. If you get the two transducer connections reversed, the until will not operate properly.

After you have put the boat back in the water confirm that you can maintain a bottom reading at all boat speeds. If not, loosen the bracket screws and tilt the transducer some more. Keep the front edge flush with the boat, but drop the back edge down a little more. If changing this angle several times does not clear up

the reading, loosen the mounting screws and slide the transducer down slightly. Repeat these adjustments until you get a clear reading. You'll most likely be looking for a balance between high speed performance and the transducers producing a "rooster tail". The further you go down below the hull, the better the transducer will perform at high speed, but the more likely it will be to result in water spray. Make sure that all mounting screws are tight when you're done adjusting.

### Trolling Motor Mounting

Install the transducers into the one-piece trolling motor mounting bracket as shown. Use the two included large cable ties to attach the transducer to the electric trolling motors lower unit. Using the slots in the transducer bracket, run the ties through them and around the motors lower unit. Locate the transducers on the bottom of the lower unit as shown. Locate the 107 kHz transducer towards the front of the motor. This transducer is more susceptible to turbulence, so keep it further away from the propeller.

Run the cables up the shaft using smaller cable ties or electrical tape to hold it them in position. Make sure that the cables will not be damaged by the movement of the trolling motor. Plug the transducer connectors into the back of the unit and tighten the retaining rings. Make sure the frequency label on the transducer cable matched the frequency labeled on the transducer jack on the unit. If you get the two transducer connections reversed, the until will not operate properly.

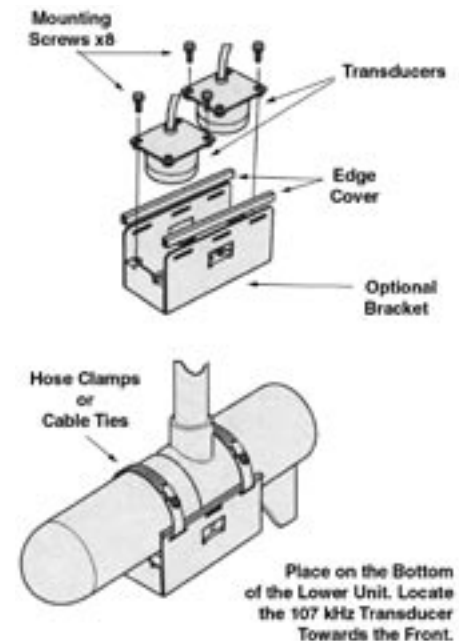

## In-Hull Mounting

Finding the best location for the transducers before mounting is critical. Choose a flat smooth spot near the center of the bilge and near the back of the boat. It is a good idea to make a "test run" before you permanently install each transducer. This makes sure that you can, indeed, get a reading through your hull, and when the boat is on plane. Put about a half inch of water in the bilge and hold the transducers in the intended location. Move the transducers around until you get the best reading. Mark the spot.

Surface preparation and location are the keys to having a good sonar transducer installation that will last for years, so please take a few extra minutes to prepare the surface area. Also, the temperature should be at least 60° F while performing the installation.

Select an area inside your boat to mount each transducer. Try to keep the two transducers as close together as you can. Ideally, for reliable high speed operation, you will need to place the transducers near the center of the transom area of the boat, which is often near the drain plug. You must attach each transducer to a solid hull area, this means you cannot have a double hull aluminum or a foam layer in the fiberglass between the transducers and the water.

It is critical you find a smooth, flat spot to place your transducers. Small ridges, bumps or even paint under a transducer will affect the quality of the sonar signal. Your Edge comes with two surface preparation kits, each including a Scotch-Bright® pad to smooth any rough areas and to help get you down to the base material for a secure install.

Use the supplied cleaning patches of Isopropyl Alcohol to remove dust and dirt from the target areas you are mounting to. Be sure to also wipe clean the faces of your transducers. Use a paper

towel or dry cloth to finish the clean-up of the areas. Let dry for a few minutes.

Place the transducers exactly where you want to install them. Apply four supplied positioning pads around each transducer. The positioning pads are needed to prevent your transducers from drifting off the target area while the A.C.E. adhesive sets up.

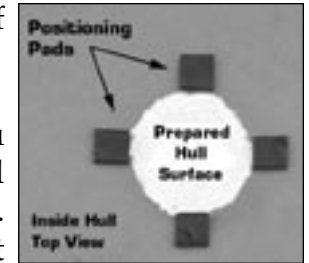

Use one packet of A.C.E. for each transducer and attach one transducer at a time. Follow the mixing directions on the packet of A.C.E. Adhesive and apply the entire packet directly to the face of one transducer. Place the transducer into position. Press firmly and twist slightly back-and-forth to work-out any air bubbles that might have been trapped in the epoxy.

**IMPORTANT:** Do not power-up your Edge for at least 12 hours. Doing so will effect adhesive curing, allowing air pocket to form between the transducers and the hull. This will ruin your installation efforts.

## Installing the Temperature Probe

Install the temperature probe in a suitable location. If you install it on the transom of your boat, use the two screws provided to attach it to your transom or transom mounting plate. Be sure not to mount it so it extends below the bottom of the hull. It only needs to be below the water line to function properly.

If you install it on your electric trolling motor, use a small cable tie to secure it to the trolling motor bracket as shown.



## UNIT OPERATION

The Edge<sup>3</sup> is designed to be powerful, yet extremely easy to operate. The first thing you'll want to do is get familiar with the front panel keys and their functions.

To help you learn how each feature works, the Edge<sup>3</sup> has a built-in simulator. You can turn this feature on and then be able to try out all of the controls and menu settings before you get on the water.

***REMEMBER:** If you've just installed in-hull transducers and the adhesive has not fully dried, be sure to unplug the transducers from the unit before you turn it on.*

### Turning the Unit On

To turn the Edge<sup>3</sup> on, press and hold the ON key until you hear the start-up tone. It will take a second or two to boot before you see the display light up.

### Turning the Unit Off

To turn the Edge<sup>3</sup> off, press and hold the OFF key.

### Activating the Simulator

To active the simulator mode:

1. Turn the unit on.
2. Press the MENU key three times.
3. Press the ▲ key once or the ▼ key until the cursor reaches the Simulator setting.
4. Press the ► key to highlight ON.
5. Press the USER/CLR key to exit the menu.

## UNDERSTANDING THE DISPLAY

In most situations, the Edge<sup>3</sup>'s display will be set up in the split screen mode with the 107 kHz beam on one side and the 400 kHz beam on the other. Scattered around the display are some items offering information. Refer to the figure on the next page and the following explanations to help you understand what the different items on the Edge<sup>3</sup> display indicate.

**Beam Frequency** - Indicates the operating frequency of the beam for each screen. If the system is set to only show one beam, the frequency of it will show on the far left.

**Beam Gain Level** - Indicates the level of the gain by both a digital number and a bar graph.

**Auto** - Indicates that the Auto Range (R) or Auto Gain (G) control is on. If no letter shows, it indicates the unit is in manual range or gain mode.

**Current Range Scale** - Indicates the currently selected range for each beam. The number at the bottom of the column shows the maximum depth the unit can read when set to this range.

**Water Surface Temperature** - Indicates the temperature of the water as reported by the temperature probe.

**Battery Voltage** - Indicates the voltage of the power supply that is providing power to the Edge<sup>3</sup>.

**Clean Line Level** - Indicates the level of the Clean Line feature for each beam.

**Water Depth** - Indicates the depth of water. In split screen mode, this number is determined by the right beam.

# OPERATION

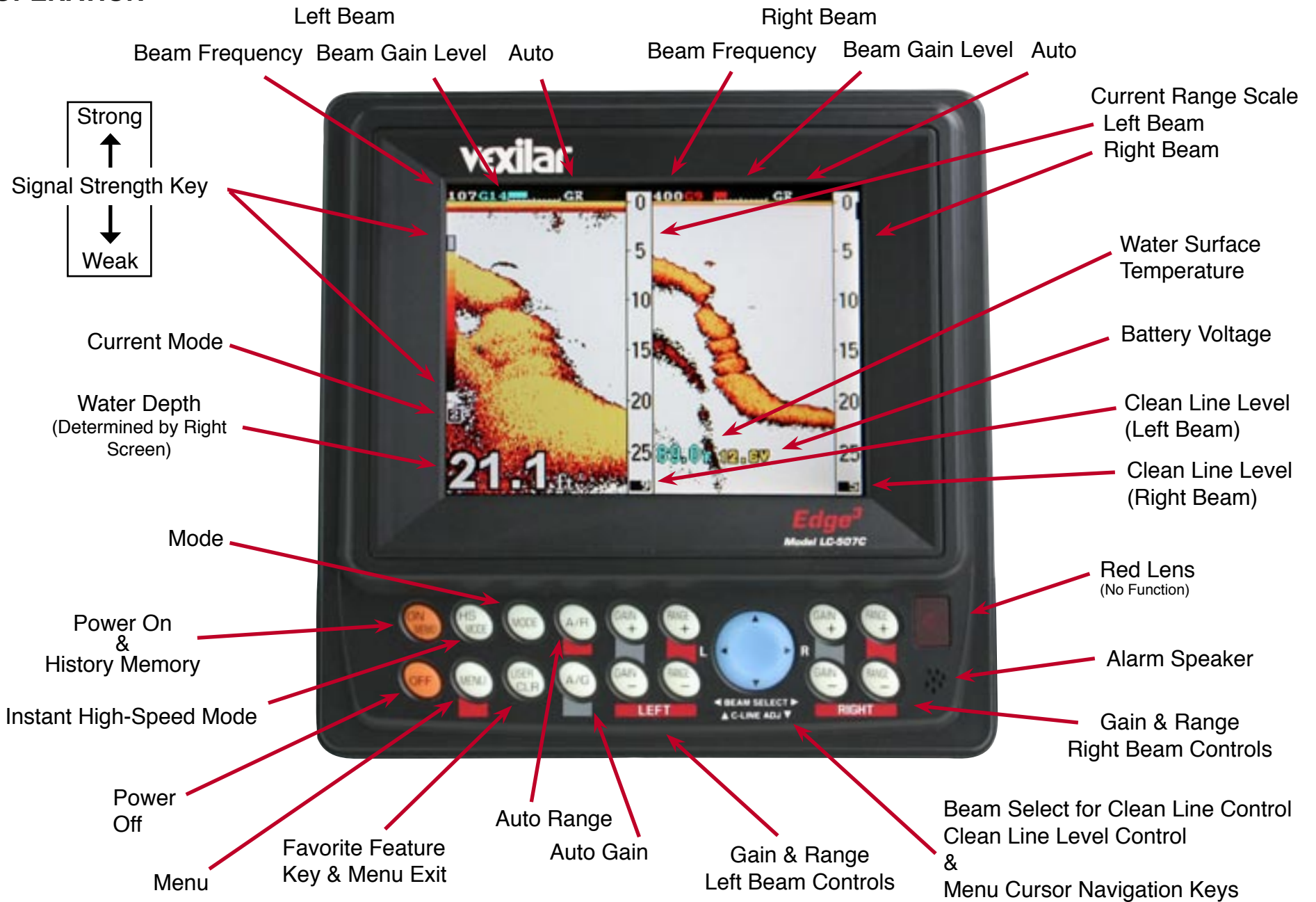

**Current Mode** - Shows the currently active mode (1 - 4)

**Signal Strength Key** - Shows the color versus signal strength for the selected color scheme. The stronger colors are represented towards the top of the key and the weaker color towards the bottom. The upper most color is the Clean Line color.

## CONTROL PANEL KEYS

**ON / MEMO** - Push and hold to turn the unit on.

When the unit is on, push to activate the Memory Mode. Push the ► and ◀ buttons to review the last X screens of history. Push again to exit the Memory Mode.

**OFF** - Push and hold to turn the unit off.

**HS MODE** - Push to enter the Instant High Speed Mode. The unit will shift to its maximum speed of 40 pixels per second. Auto Range and Auto Gain features are disabled in this mode.

**MENU** - Push to enter the Edge<sup>3</sup>'s menu. Push repeatedly to change to subsequent menu pages.

**MODE** - Push to change to the next Mode. Selections entered for the current Mode will be saved.

**USER / CLR** - Push to activate the configured "Favorite Feature". A small menu item will appear in the upper left part of the display. Press again to change the menu setting or use the ► and ◀ keys to change the current setting. The small menu will automatically exit three seconds after the last key is pressed. See the section on Menu Settings to learn how to configure this key.

When in Menu Mode, press this key to exit (clear) the menu.

**A / R** - Push to toggle on and off the Automatic Range Control feature. When Auto-Range is on, an "R" will show at the top of each beam display. The Auto-Range feature maintains the best view of the bottom, according to the A-RNG-MODE menu setting for each beam.

When this feature is off, you will need to manually change the range setting using the RANGE + and RANGE — keys to keep the bottom in view over various water depth changes.

**A / G** - Push to toggle on and off the Automatic Gain Control feature. When Auto-Gain is on, a "G" will show at the top of each beam display. The Auto-Gain feature tries to maintain the optimum gain level for the current depth, according to the A-GAIN-LEVEL menu setting for each beam.

When this feature is off, you will need to manually change the gain setting using the GAIN + and GAIN — keys to maintain the preferred gain level.

**GAIN +** - Push to increase the gain level. When in Auto-Gain mode, you can temporarily increase the level, but the auto feature will readjust it again.

**GAIN —** - Push to decrease the gain level. When in Auto-Gain mode, you can temporarily decrease the level, but the auto feature will readjust it again.

*In split-screen mode, you have a set of range and gain keys for each beam. When in full-screen mode, either set of keys will control the full-screen beam.*

**BEAM SELECT / C-LINE ADJ** - The large round blue control is used to select the beam and then adjust its Clean Line level. The currently selected beam is indicated by a red colored gain level indicator. Press the ◀ or ► keys to change the selected beam, then press the ▲ or ▼ keys to adjust the Clean Line level.

The BEAM SELECT / C-LINE ADJ control also is used for navigation within the Edge<sup>3</sup>'s menus.

## UNDERSTANDING THE MENU

Press the Menu key to enter the first menu page, MENU 1. To change to the next menu press MENU again. You can exit any menu by pressing the USER/CLR key, or any other white key.

### Setting the Favorite Feature Key

The Favorite Feature key (USER/CLR) is a handy way to quickly access your most often adjusted menu item, by simply the press of one key. You can set the menu item the key accesses to any menu item available.

Once you've determined which feature you want to assign to the Favorite Feature key, simply highlight it using the menu navigation keys. Then press and hold the USER/CLR key. You will notice that the circle next to the menu item become filled with blue as the unit beeps. This indicates that this menu item is set as your Favorite Feature.

## MENU 1

The settings on this menu affect all Modes.

### BRIGHTNESS

This setting controls the brightness of the display. You have five levels of brightness to chose from, dim to bright. The higher the brightness, the easier the display is to see in bright conditions, but more power is required.

To change the brightness press...  
MENU --> ◀ or ▶ .

## MENU 2

The settings on this menu affect each mode, so only the currently active mode will retain the setting changes. Menu 2 is divided into two section. The top portion controls the function for the right beam, or those for full screen mode.

### RIGHT

This setting controls the frequency of the beam for the right side of the display, or the operating frequency for full screen mode.

To change the frequency press...  
MENU --> MENU --> ◀ or ▶ .

### SWEEP

This setting controls how fast the display moves across the screen, and how fast the Edge3 transmits each pulse. There are five settings from Stopped to 4. For the most accurate representation of what's below you, choose a setting that as closely matches the boat's speed as you can.

To change the sweep speed for the right beam press...  
MENU --> MENU --> ▼ --> ◀ or ▶ .

### A-RNG-MODE

Automatic Range Mode controls how the Auto-Range feature maintains the view of the bottom. It only applies when the Auto-Range feature is on. 1ST configures the system to maintain the best view of the bottom. 2ND configures the system to make sure the range setting is adjusted deeper, so you can always see a second bottom echo. 3RD insures the system will allow room for a third echo.

To change the A-RANGE-MODE for the right beam press...  
MENU --> MENU --> ▼ --> ▼ --> ◀ or ▶ .

## A-GAIN-LEVEL

Automatic Gain Level configures how the system controls the gain level when the Auto-Gain feature is on. "L" keeps the gain control on the lower side, "M" keeps it near the middle, and "H" keep the gain high.

To change the A-GAIN-LEVEL for the right beam press...

MENU --> MENU--> ▼ --> ▼ --> ▼  
then ◀ or ▶ .

## A-MODE

This setting places a vertical display at the right side of the beam view which shows an "instantaneous" view of current information. It does not speed up the update rate of the unit, but it does allow you to recognize changes more quickly than the normal view, especially at lower sweep speeds.

To activate or disable A-Mode for the right beam press...

MENU --> MENU--> ▼ --> ▼ --> ▼ --> ▼  
then ◀ or ▶ .

## FISH ALARM

The fish alarm will sound an audible alarm when the unit detects an object that is not part of the bottom. You can set it to sound on small "S" or only larger targets "L".

To active or disable A-Mode for the right beam press...

MENU --> MENU--> ▼ --> ▼ --> ▼ --> ▼ --> ▼  
then ◀ or ▶ .

## LEFT

This setting controls the frequency of the beam for the left side of the display, or to activate full screen mode. Full screen mode is activated when you select "N/A". The frequency of the single beam is determined by the RIGHT selection.

To change the frequency for the left beam press...

MENU --> MENU--> ▲ --> ▲ --> ▲ --> ▲ --> ▲ --> ▲  
then ◀ or ▶ .

## SWEEP

This setting controls how fast the display moves across the screen, and how fast the Edge3 transmits each pulse. There are five settings from Stopped to 4. For the most accurate representation of what's below you, choose a setting that as closely matches the boat's speed as you can.

To change the sweep speed for the left beam press...

MENU --> MENU--> ▲ --> ▲ --> ▲ --> ▲ --> ▲  
then ◀ or ▶ .

## A-RNG-MODE

Automatic Range Mode controls how the Auto-Range feature maintains the view of the bottom. It only applies when the Auto-Range feature is on. 1ST configures the system to maintain the best view of the bottom. 2ND configures the system to make sure the range setting is adjusted deeper, so you can always see a second bottom echo. 3RD insures the system will allow room for a third echo.

To change the A-RANGE-MODE for the left beam press...

MENU --> MENU --> ▲ --> ▲ --> ▲ --> ▲  
then ◀ or ▶ .

## A-GAIN-LEVEL

Automatic Gain Level configures how the system controls the gain level when the Auto-Gain feature is on. "L" keeps the gain control on the lower side, "M" keeps it near the middle, and "H" keep the gain high.

To change the A-GAIN-LEVEL for the left beam press...

MENU --> MENU--> ▲ --> ▲ --> ▲  
then ◀ or ▶ .

## A-MODE

This setting places a vertical display at the right side of the beam view which shows an "instantaneous" view of current information. It does not speed up the update rate of the unit, but it does allow you to recognize changes more quickly than the normal view, especially at lower sweep speeds.

To activate or disable A-Mode for the left beam press...

MENU --> MENU--> ▲ --> ▲  
then ◀ or ▶ .

## HARD-BTM-ALM

The Hard Bottom Alarm will sound an audible alarm when the unit detects a second echo. It will only function when the A-RANGE-MODE feature for the left beam is set to 2ND or 3RD

To activate the Hard bottom Alarm press...

MENU --> MENU --> ▲ --> ◀ or ▶ .

## MENU 3

Menu 3 controls items such as the display color, zoom, and the temperature alarm. The settings on this menu affect all Modes.

### BACK-GRD

This setting changes the color of the display's background. Choose a background color based on personal preference and visibility. There are four choices; White, Light Blue, Black, and Dark Blue.

To change the background color press...

MENU --> MENU --> MENU --> ◀ or ▶ .

### COLOR

The color setting allows you to change the color scheme for the 16 display colors. Each color represents a different strength return signal. Choose a color scheme based on personal preference and visibility. There are six choices.

To change the background color press...

MENU --> MENU --> MENU --> ▼  
then ◀ or ▶ .

### ZOOM

Zoom magnifies the specified area of the right beam. It is useful for detecting targets that are very close to the bottom or that are very close together in deeper water. There are two forms of zoom; Auto maintains a zoomed view of the bottom, and Manual maintains a zoomed view of an area you specify. The zoomed beam is determined by the right beam. The left beam will no longer be visible when zoom is activated.

To active the zoom mode press...

MENU --> MENU --> MENU --> ▼--> ▼  
then ◀ or ▶ .

## Adjusting the Manual Zoom

To adjust the manual “zoom zone”, exit the menu and then use the RANGE + and RANGE — keys for the left beam on the front panel. You will notice a green bar on the right side of the right beam moves as you make adjustments. Align the green bar with the area you want to magnify. This indicates the area that will appear zoomed on the left side of the display.

## ZOOM-RATE

The zoom rate determines the amount of magnification. You have magnification choices of x2, x4, and x8. For flatter bottoms, you can choose x8. For greatly undulating bottoms, use x2.

To change the zoom rate press...

MENU --> MENU --> MENU --> ▼ --> ▼ --> ▼  
then ◀ or ▶ .

## HARD-BTM-LEVEL

This setting turns on and off the hard bottom level indicator and graph. When activated, a pink colored graphical display is added below the right beam, or entire beam in full screen mode. In addition, a large pink digital number is also added in the upper left corner of the display. The number will vary from 0 to 20, depending on the hardness of the bottom. The graph will show changes over time and corresponds to the bottom display. This allows you to easily see where the bottom content changes.

To activate or disable Hard Bottom Level press...

MENU --> MENU --> MENU --> ▼ --> ▼ --> ▼ --> ▼  
then ◀ or ▶ .

## COMPOSITE

Composite mode places the 107 kHz beam and the 400 kHz beam on top of each other. Objects that are only visible with the 107 kHz beam are represented by a gray scale color scheme. Objects only visible with the 400 kHz beam are represented by a green color. Objects visible with both beams are colored red. In order to activate the Composite mode, you must first be in split screen mode.

To activate or disable Composite mode press...

MENU --> MENU --> MENU --> ▲ --> ▲ --> ▲  
then ◀ or ▶ .

## TEMP-ALARM

The temperature alarm gives you the ability to sound an audible alarm when the water surface temperature falls within a specified zone or outside a specified zone.

To enter the Temp Alarm sub-menu press...

MENU --> MENU --> MENU --> ▲ --> ▲  
then ▶ .

To activate the alarm press ▶ once for the “In-Range” alarm and twice for the “Out-Range” alarm.

To turn the Temperature Alarm off, press ▶ repeatedly until OFF is displayed.

To adjust TEMP-SET-1 (the lower temp value) press ▼

then ◀ or ▶ to adjust the value.

To adjust TEMP-SET-2 (the upper temp value) press ▼ --> ▼

then ◀ or ▶ to adjust the value.

Press the MENU key to exit the Temp Alarm sub-menu.

## MENU 4

The fourth and final menu contains controls for some basic functions and unit of measure settings.

### SUPER RANGE

Super Range controls the way the display appears when the depth range changes. When Super Range is OFF, and the range changes, you will see the point at which the range changed on the display. This point will scroll across the screen until it disappears at the far left side. When Super Range is ON, there will be no visible point at which the depth changed. Super Range adjusts the entire display to the new range.

To activate or disable the Super Range feature press...

MENU --> MENU --> MENU --> MENU (HOLD)  
then ◀ or ▶ .

### PULSE-LENGTH

Pulse Length controls how long each "ping" of the transducer is. Longer pulse lengths allow better deep water performance but reduce resolution. Shorter pulse lengths give the best resolution, but have problems reaching into deep water.

To change the Pulse Length press...

MENU --> MENU --> MENU --> MENU (HOLD)  
then ▼ and then ◀ or ▶ .

### STC

STC stands for Surface Time Control. Its function is to reduce the surface clutter normally found in the first few feet of the water column by reducing the gain in this region.

To activate or disable STC press...

MENU --> MENU --> MENU --> MENU (HOLD)  
then ▼ --> ▼ and then ◀ or ▶ .

## DEPTH

The Depth feature controls how the digital depth number appears at the bottom of the display. Your choices are OFF, S (Small), or L (Large). OFF turns off the digital depth and all other digital indications. Small displays the digital depth and other indicators. Large makes the digital depth appear larger and easier to read. The other indicators stay the same size.

To change the Depth setting press...

MENU --> MENU --> MENU --> MENU (HOLD)  
then ▼ --> ▼ --> ▼ and then ◀ or ▶ .

### DEPTH-UNIT

This feature lets you choose between Meters and Feet for depth measurement.

To change the Depth-Unit setting press...

MENU --> MENU --> MENU --> MENU (HOLD)  
then ▼ --> ▼ --> ▼ --> ▼  
and then ◀ or ▶ .

### TEMP-UNIT

This feature lets you choose between Celsius and Fahrenheit.

To change the Depth-Unit setting press...

MENU --> MENU --> MENU --> MENU (HOLD)  
then ▲ --> ▲ --> ▲ --> ▲  
and then ◀ or ▶ .

## TEMP-ADJ

This feature allows you to calibrate the temperature reading, if necessary.

To modify the temperature reading press...

MENU --> MENU --> MENU --> MENU (HOLD)

then ▲ --> ▲ --> ▲  
and then ◀ or ▶ .

## VOLT-ADJ

This feature allows you to calibrate the voltage reading, if necessary.

To modify the temperature reading press...

MENU --> MENU --> MENU --> MENU (HOLD)

then ▲ --> ▲  
and then ◀ or ▶ .

## SYSTEM-RESET

System Reset will revert all settings back to the factory originals. This can be handy for trouble shooting erratic operation or simply getting the setting back to a known state.

To perform a System Reset press...

MENU --> MENU --> MENU --> MENU (HOLD)

then ▲ --> ▶ --> ◀ .

*System Reset will cause the lose of all modified settings.*

## ACCESSORIES & REPLACEMENT PARTS

### Depth

TBX071	107 kHz Transducer	\$79.00
TBX072	400 kHz Transducer	\$79.00
CB0001	10' Transducer Extension Cable	\$24.00
CB0002	20' Transducer Extension Cable	\$29.00
HSB003	Transducer Transom Bracket	\$5.00
TBH001	Transducer Transom Housing	\$3.00
BKT003	One-Piece Transducer ETM Bracket	\$18.00
ACE001	A.C.E. Transducer Adhesive	\$8.00

### Temperature

TPX002	Temperature Probe	\$39.00
CB0003	10' Temp Probe Extension Cable	\$35.00

### Mounting

GBX003	Unit Gimbal Bracket	\$20.00
GKX003	Gimbal Bracket Knob	\$2.30
PCX002	Power Cord with Fuse	\$16.00

### Switch Boxes

SB-100*	Switch Box - 2 transducers on 1 unit	\$45.00
SB-200*	Switch Box - 2 units on 1 transducer	\$45.00

*\*You need one switch box for each beam.*

*Prices subject to change without notice*

## TROUBLE SHOOTING

Symptom	Possible Cause
Unit will not turn on.	Check for proper battery polarity and that you have fully charged, working batteries.
Unit is turned on, but there is no display.	Contrast is adjusted too low. Increase contrast.
Unit runs well for a short time, then the unit quits.	Bad battery or poor connection. Check voltage level under load and all electrical connections.
Unit runs and shows display light, but does not read depth.	Transducer is not plugged in or not in contact with the water.
Unit works, but needs high gain to see bottom or targets.	Transducer is not aimed correctly or needs to be cleaned.
Unit works, but has too many lines on the display. Can't tell what is what.	Many air bubbles or very small targets in the water. Electrical noise from another device.
Unit works well when sitting still or at slow trolling speeds, but loses reading when the boat speeds up.	Improper transducer installation or adjustment. Loss of clear water flow across the face of the transducer when the boat reaches a certain speed.
Unit works, but shows noise when the engine is started or the electric trolling motor is turned on.	Improper ground or missing ground in electrical system. Defective engine or trolling motor.
Temperature does not show or is not accurate.	Temp sensor is not plugged in or is not in the water.

If this trouble shooting guide does not help, please contact our customer service department.

## SERVICE AND SUPPORT

If you find that you need help, feel free to contact us. Please have ready the model number and, if possible, the serial number of your product. Be sure to read the Trouble Shooting sections first.

### Address

Vexilar, Inc.  
6667 W Old Shakopee Road  
Minneapolis, MN, 55438

### Telephone

(952) 884-5291 (8 am to 5 pm M-F Central Time)

### Fax

(952) 884-5292

### Web Site

[www.vexilar.com](http://www.vexilar.com)

### Email

[service@vexilar.com](mailto:service@vexilar.com)